

Infinity's Case Packer for Bottles (ICB-120)

Infinity's Case Packer for Bottles (ICB-120)

Infinity's Automated Case Packer is a fully integrated and 100% servo-driven case packaging system, matching the speed, accuracy, and efficiency requirements. System is expected to be integrated with high-speed primary bottle filling line.

The products are travelled on a conveying technology to enable easy product pitch creation and creating a uniform travelling path. The bottles are then passed through state of the art Lane Divider system. The lane divider is completely servo driven for precise bottle handling and creating desired matrix. The system is equipped with project specific Robotic Pick & Place application for précised product handling and feeding inside the cartons. For double assurance our gripper mechanism utilizes mechanical and vacuum suction cups, enabling accurate product placement.

At the same time, we have carton erectors with bottom taping, carton closures and transfer for next processes. Optional quality assurance is provided using a weighing scale, to ensure only 100% conforming products are delivered.

This system adds value proposition with unbeatable flexibility inside of a small, space-saving footprint. The main performance advantage of our top load pick-and-place machine is its ability to achieve higher throughputs while simultaneously multi-tasking. All of this is achieved synchronously while securing case flaps and picking and placing products – all inside the shortest of cycle times and within a compact footprint.

This rugged, compact system contains everything to boost top loading output. Its rotors were chosen to deposit flexible bags into cases and enable the machine to pack a wide variety of pack patterns at high speeds. Its open design provides exceptional visibility of the entire packaging process. This allows for fast and easy training of operators.

System Layout

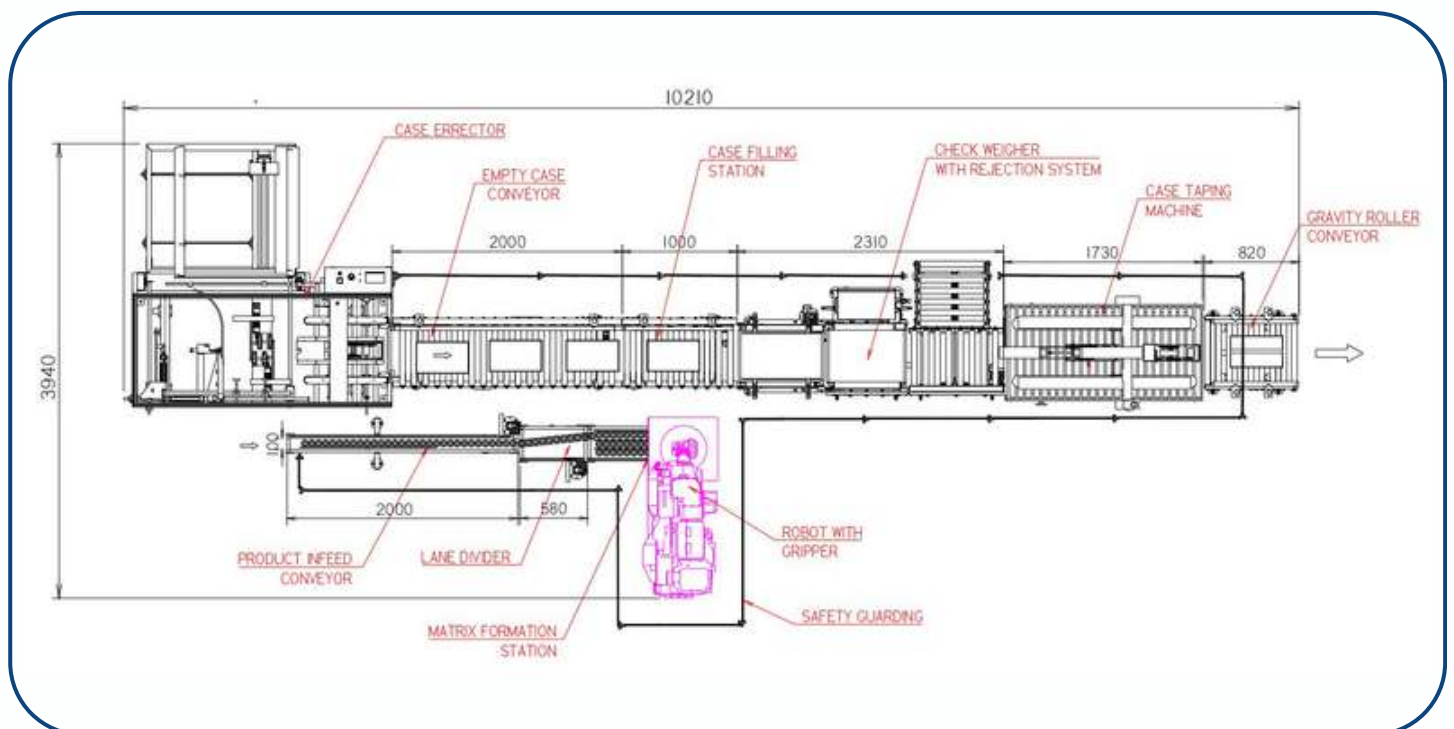

Technical Specifications & Features

- System Dimensions – Project Specific Customized Solution
- Desired Matrix formation
- Minimal Changer over for handling multiple variants
- Specialized grippers & suction capabilities
- Flexibility for Pick & Place of Gantry System
- Optional Inline Capabilities: Check Weigher, Taping, Label Application Printing
- Input Speed- Upto 120 PPM (product dependent)
- Out Put Speed: Upto 8-10 cases per minute
- Air requirement: 6 CFM (Approx)
- Power required: 3 Phase 420V AC / 50 Hz
- Electrical Consumption: 8KW Approx
- MO MS & Contacts parts: SS-304
- High-Speed, Accuracy & Precision Servo Driven system
- Can be integrated with any bottle filling line.
- Tower lamp to identify machine status
- 7" Color Touch screen with 50 Recipe function

System Advantages

- Eliminates extensive manpower
- Compact & Modular Design
- Reduces overall packaging costs
- Enhanced quality control
- Easy product setup & changeovers
- Delicate product handling

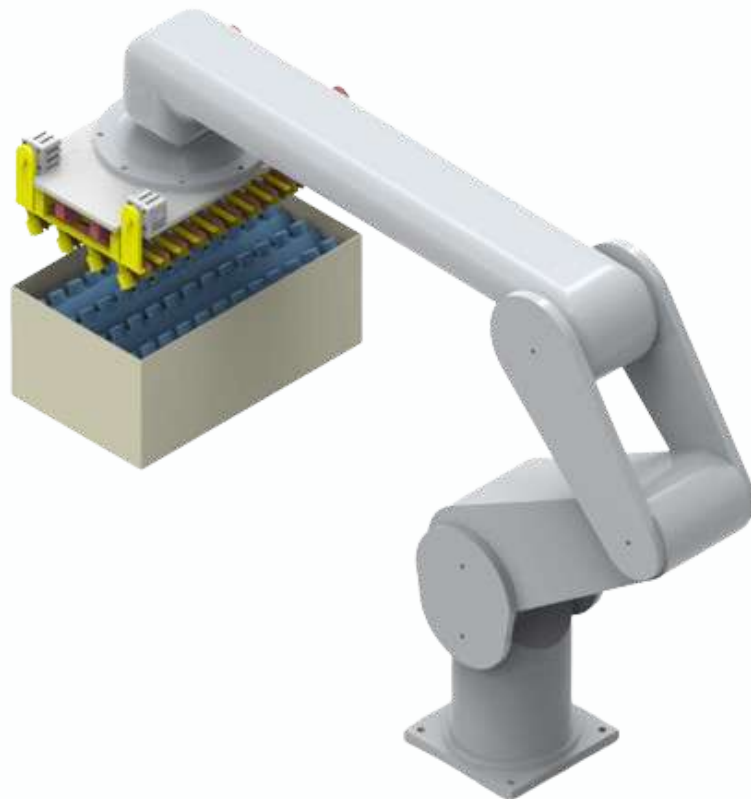

Disclaimer: The specifications and image provided in this product catalog are general and subject to variation based on specific customer requirements. Changes may occur without prior intimation. For precise details, please refer to the technical layout provided with offer for exact specifications.

Our Customers



**"World Class End-Of-Line Packaging
Automation Solutions For Diverse Industries"**

 +91 8484922042

 info@infinitysols.com

 www.infinitysols.com

 [infinity-automated-
solutions-pvt-ltd](https://www.linkedin.com/company/infinity-automated-solutions-pvt-ltd)

 [infinitysols1](https://twitter.com/infinitysols1)

 [@Infinitysols](https://www.youtube.com/@Infinitysols)

 [iaspune](https://www.facebook.com/iaspune)

 [infinitysols](https://www.instagram.com/infinitysols)



Plot no: 6 & 17, Sr. No: 1556 / 1559, Shelar Wasti, Dehu-Alandi Road,
Chikhali, Tal: Haveli, Dist: Pune 412114, Maharashtra, India