

# Flat Belt Conveyor

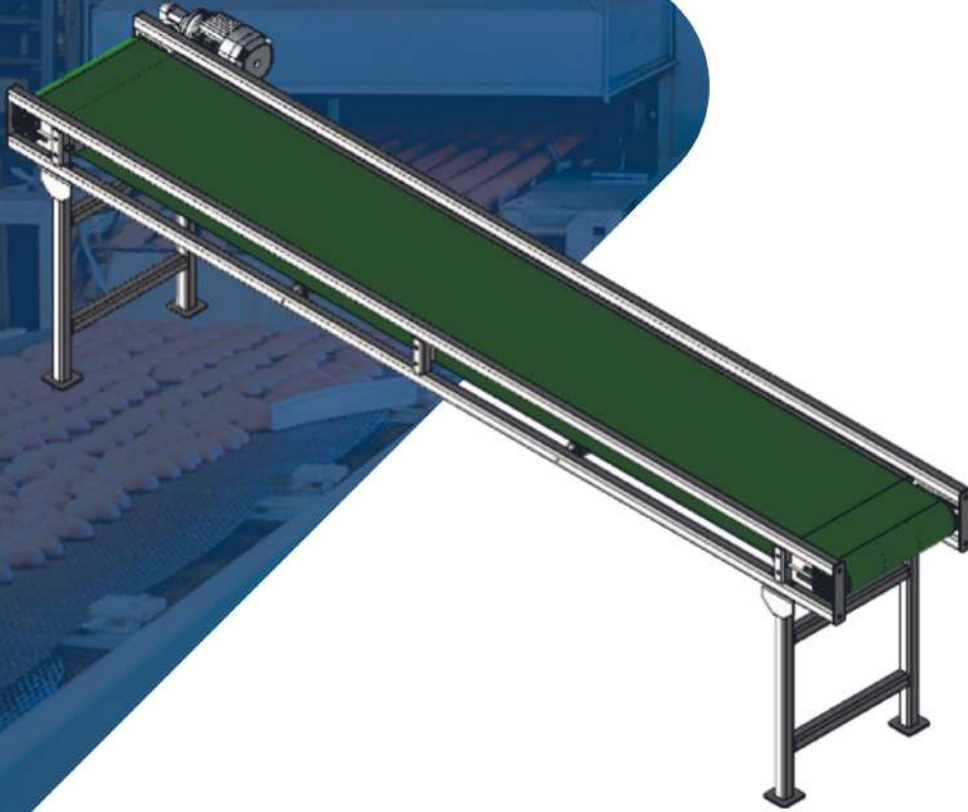

This Infeed Belt Conveyor is specifically considered for connecting products coming out of primary line and transferring it for further operations. considered for The delivery conveyor is designed with several ergonomic features minimizing fatigue of the operator when handling products in high-speed applications. Two stage height adjustment on each end of the conveyor allows for quick adjustment of table elevation, based on operator preference. Variable speed with batching ability provides gaps eliminating needs for counting finished product, while increasing productivity.

## Features:

- Conveyor Type Infeed Belt Conveyor
- Speed 48 -60 PPM
- Gearmotor - MGM  
Warvel/Bonfgloli/Bonvario
- Belt Width - 220 mm
- Pick Up Height: 830 (Project specific customization)
- Bearing Type at Drive End - Pillow Bearing
- Side Guard - Screw Guided Guard
- Pick up Height - Project Specific
- Conveyor Length - Project Specific
- Contact Part MOC - SS304
- Structure - MS Powder Coated
- Foot Mount - Leveling Foot Mount +/- 50mm
- Universal mounting for integration with 3rd party equipment
- Height adjustment with locking casters
- Shingling rollers with mounting assembly
- Emergency Stop pendent

## Usage / Application

**FOOD, SPICES, DAIRY,  
PHARMA, ICE CREAM,  
COLD STORAGE  
AND WAREHOUSES**

Disclaimer: The specifications and image provided in this product catalog are general and subject to variation based on specific customer requirements. Changes may occur without prior intimation. For precise details, please refer to the technical layout provided with offer for exact specifications.