

Material Conveying Systems

Z Shape Bucket Elevator

It is used to transfer material like grains, pulses, wafers, namkeens, fryams from floor level to the desired height and distance.

Features :

- Totally dust proof enclosure for avoiding foreign particles in material
- Elevator is provided with wheels for easy relocation
- The elevator is provided with level sensors & control, so it accurately controls the material flow and maintains the machine hopper level
- Elevator is provided with safety switches for protecting operator from accidents
- Elevator is equipped with electrical safety for reverse polarity, single phasing and overload of motor
- Inching feature is given, so the buckets can be moved slowly by pressing a push button, this helps in cleaning the buckets

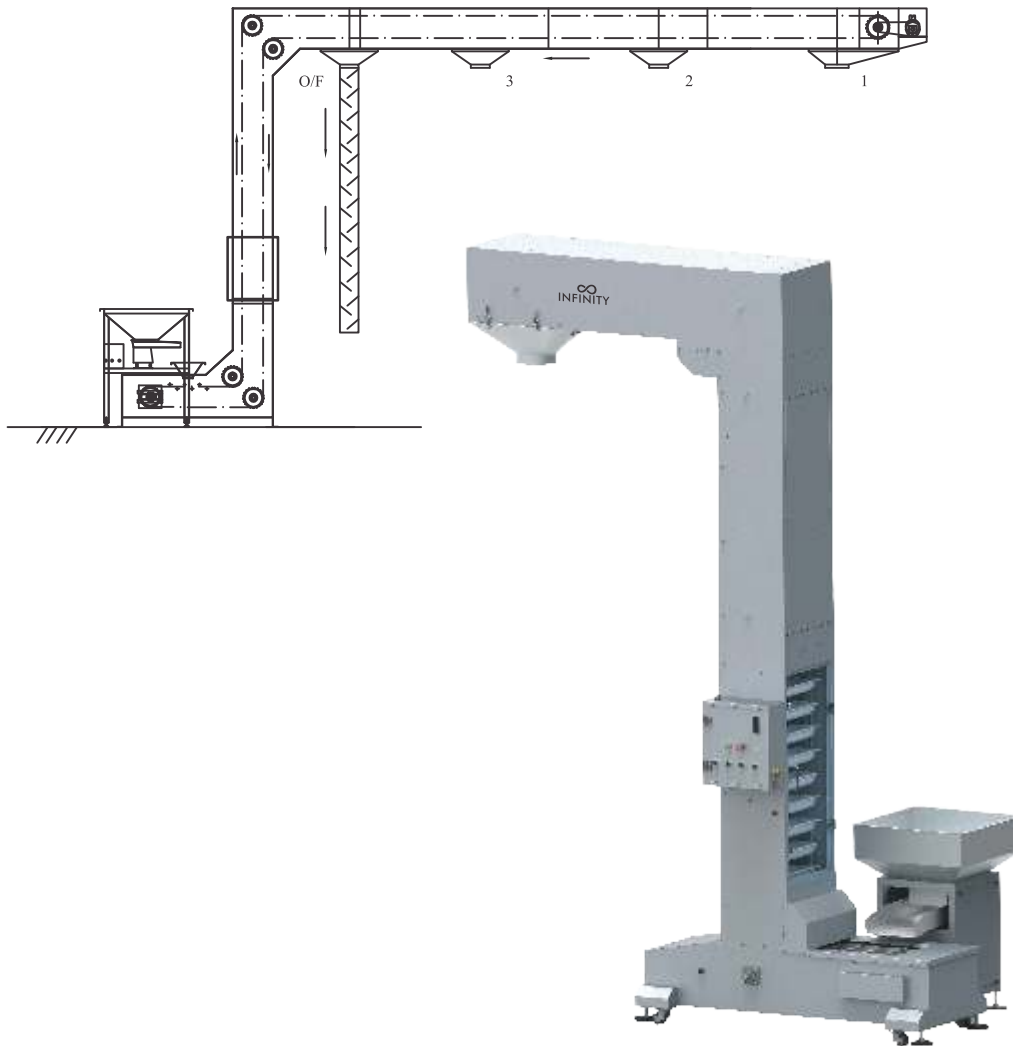

General Specifications :

Bucket Capacity	2 ltr or 3 ltr (optional)
Material Feeding Height	500 mm (adjustable 50 mm)
Material Dropping Height	2 mtrs to 12 mtrs (can be customized)
Output	300 to 600 ltr/min
Construction	MS powder coated or SS 304 (optional)
Drop Stations	1 or multiple